

SERVICE BULLETIN

STINSON DIVISION
CONSOLIDATED VULTEE AIRCRAFT CORPORATION
WAYNE, MICHIGAN

TITLE: Leakage - Cabin Door Windows

BULLETIN NO. 247

MODELS AFFECTED: 108-1990 through 108-2394

PAGE 1 OF 1

DATE: April 29, 1947

Gentlemen:

There has been reported a few cases of where rain has filtered into the cabin interior through the upper and lower rear corners of the cabin windows on airplanes within the above serial numbers.

This is not a mandatory correction, but should the problem be encountered we recommend that the aft ends of the upper and lower sliding window track be treated with a sealing compound. The track in the cabin door should be filled with sealer for a distance of about one inch forward of the rear window frame. Using a putty knife or similar tool the sealing compound should be pressed well into the channel making sure that the aft edge of the channel and window frame are sealed. The sketch below illustrates only the lower corner, but the upper corner should be similarly treated. The following types of sealing compounds are recommended:

Mastiseal - Ditzler Color Company
Alumilastic C-2 - Parr Paint and Color Company
Zinc Chromate Compound - Equivalent of AAF Spec. 3598,
Cond. B.

For compliance with this bulletin, where necessary, we will allow one direct labor hour per airplane at our regular warranty rate. All claims for labor allowance under this bulletin must be filed within ninety days from date of bulletin issuance.

Airplanes serial number 2395 and up will be sealed at the factory.

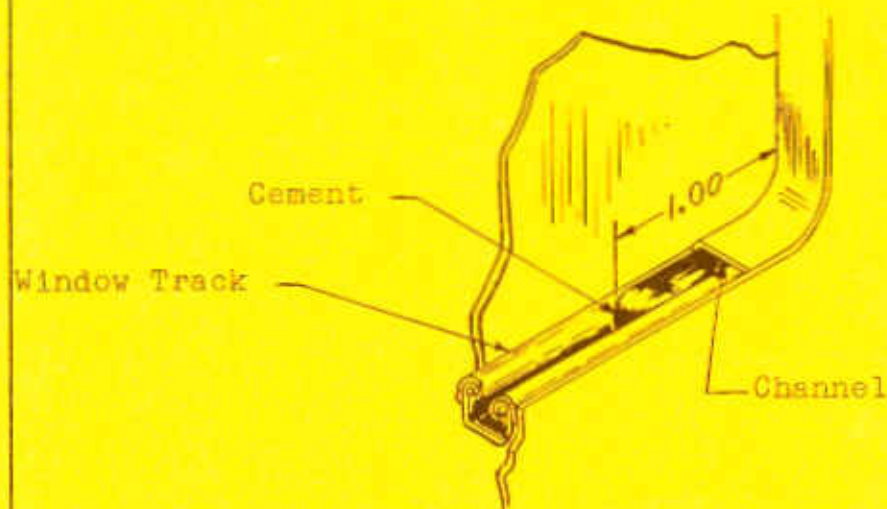

George Martin

George Martin
Service Manager